

(주)케이투엔 K2N Co.,Ltd

200-926 강원도 원주시 호저면 막골길 74-4
 #74-4 Makgolgil, Hojeo-myeon, Wonju-si, Gangwon-do 200-926, Korea
 Tel : +82 33 743 4997 Fax : +82 33-743-5994
 E-mail : sky@skyvalve.co.kr Website : http://www.skyvalve.co.kr

SKY LINED BUTTERFLY VALVE



CONTENTS

- Introduction of Valve**
- Features of Valve
- Lining Materials
- Exploded View**
- Materials**
- Features of Valve**
- A-A Detail
- Dimension**
- Valve Torque
- Valve Flow Coefficient**
- Direction for the use of Valve**
- Maintenance**



INTRODUCTION OF VALVE

Applications and Specifications of Valve

밸브의 일반적 용도 및 사양

Applications

Semiconductor / LCD chemical manufacturing
 Petrochemistry
 Polysilicon / silicon
 Steel manufacturing plant / paper manufacturing
 Chemical plant
 Food and medicine

Specifications

Model : SKY PFA lined butterfly valve
 Size : 50A ~ 900A(WAFER), 50A ~ 600A(LUG)
 Flange standard : JIS 10K, ANSI 150lbs, PN 10
 Temperature range : -20℃ ~ 200℃
 Maximum pressure : 1.0MPa

일반적 용도

반도체 / LCD 제조용 CHEMICAL 산업
 석유화학공업
 폴리실리콘 / 실리콘 산업
 철강 / 제지산업
 일반화학공업
 식품 / 의약품 산업 등

사양

모델 : SKY PFA lined butterfly valve
 사이즈 : 50A~900A(WAFER), 50A~600A(LUG)
 면간 : TABLE 참조(P.5)
 FLANGE규격 : JIS 10K,ANSI 150lbs, PN 10
 사용온도범위 : -20℃ ~ 200℃
 최고사용압력 : 1.0MPa

Seat Liner

Valve Design : API 609,DIN EN1092, JIS B2032
 Face to Face : ASME B16.10, DIN 2532, JIS B2212
 Flange Adaptability : ASME B16.10, DIN 2532,
 JIS B2212

Operator Available

Lever Handle, Gear Operator, Pneumatic and
 Electric Actuators

Inspection & Testing : API 598, DIN 3230, JIS B2003
 Mounting Flange : ISO 5211

Lining Material

SKY VALVE uses virgin resin of well-known brand to produce its PTFE, PFA fluoropolymers.
 Especially for lined valves, factors including liner thickness, resin quality and fabrication expertise always are more significant to affect valve performance and its service life

SKY VALVE는 유명 브랜드의 레진을 사용하여 PTFE,PFA,FEP 등을 생산합니다. 특히 라인드 밸브의 경우 라이너 두께, 수지 품질 및 제작 전문 지식은 밸브의 성능과 수명에 영향을 미칠 수 있습니다.



Seat Liner

- Materials shall be PTFE, PFA and FEP
- Molded and machined with min, 3mm nominal thickness

- 재료는 PTFE, PFA 또는 FEP를 사용합니다.
- 최소 3mm 두께로 성형 및 가공됩니다.

More information about selection of appropriate liner material for a given service, please consult manufacturer.

Disc lining

- Fully lined with PTFE or PFA
- Encapsulated with a min, 3mm thick PTFE or PFA

- PTFE 또는 PFA로 라이닝이 됩니다.
- PTFE 또는 PFA의 두께는 최소 3mm로 되어있습니다.



EXPLODED VIEW

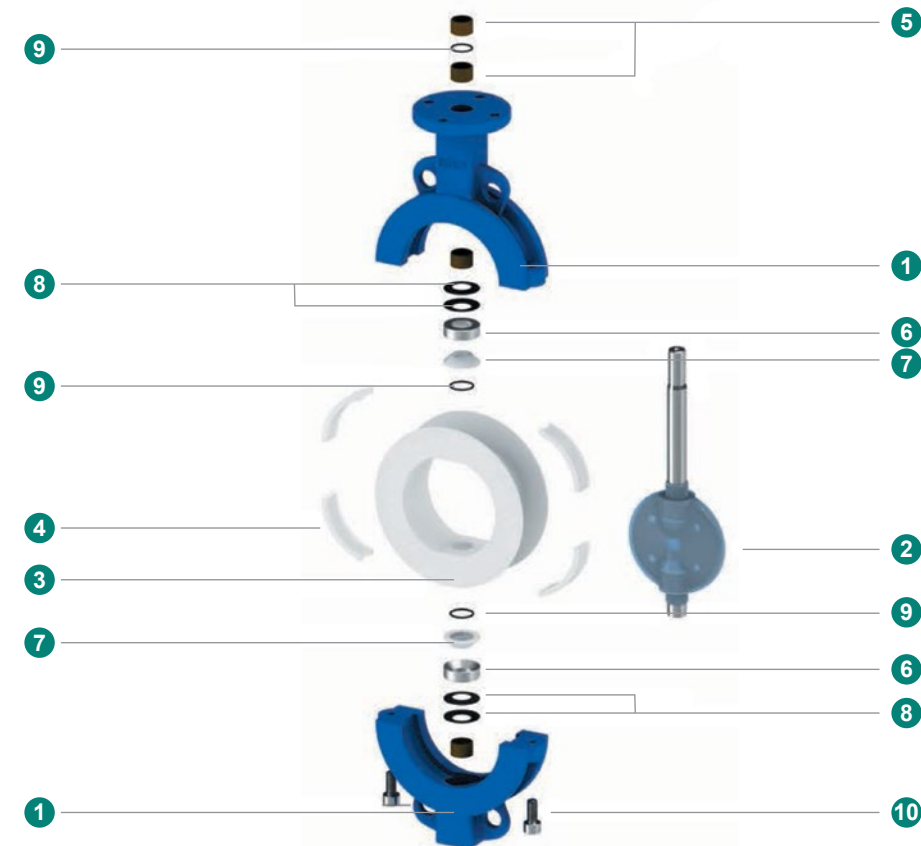

MATERIALS

No.	Description	Qty.	Materials	Materials According to Norms		
				ASTM	JIS	DIN
①	BODY	2	Carbon Steel	A216-WCB	G5151 SCPH2	GS-45(1.0446)
			Stainless Steel	A351-CF8	G5121 SCS13A	G-X6CrNiMo1810
			Ductile Iron	ASTM A395	FCD400	GGG-40(0.7040)
②	ONE-PIECE DISC	1	Carbon Steel	A216-WCB	G5151 SCPH2	GS-45(1.0446)
			Stainless Steel	A351-CF8	G5121 SCS13A	G-X6CrNiMo1810
			Ductile Iron	A536-60-40-18	FCD350-22	1693-1997GGG-35,3(0.7033)
③	BODY LINER(SEAT)	1	PTFE/UHMWPE/PO/PE/FEP/PFA	-	-	-
④	ELASTIC SPACER	2	Silicone Rubber	-	-	-
⑤	AXLE SLEEVE	4	Carbon Steel + PTFE	1020 + PTFE	S20C + PTFE	C20 + PTFE
⑥	TAPER SEAL CARTRIDGE	2	Carbon Steel	1020	S20C	C20
⑦	TAPER SEAL RING	2	PTFE	-	-	-
⑧	BELLEVILLE SPRING	4	Spring Steel	E52100	Su52	100Cr6
⑨	O-ring	3	VITON	-	-	-
⑩	HEX BOLT	2	Stainless Steel	A 182 F304	G4303-SUSF304	X5CrNi18 10 DIN 17440

FEATURES OF VALVE

Stem design(Square, double-D, single key, double key)

Self lubricating bushing could endure under pressure and three point from SL design could prevent disc be deformed

Double belleville springs exert uniform loading through the pusher, pressing the PTFE seal ring and the shoulder of the disc hub together resulting in a leak free mechanical stem seal

O-ring(the second seal)

Elastomer back-up immersed in body ensures zero leakage between disc and seat

Two piece body(water and lug type) precision casting moulds clear mark

ISO5211 pad universal mounting permits easy automations even with the valves in the pipe line

Integral body locating holes to ensure perfect centering of the valves between flange. Applied to different international standard

PTFE seat Precision machinery processing, extra wide spheroidal seat design provides positives shut off(the primary seal)

Taper metal seal cartridge (the thrid seal)

Taper PTFE sealing seal

One piece disc-stern, blow out-proof machined, Rated for full vacum and thernalcycling. Minimum lined thickness 3mm eliminates permeations and possible delamination

Epoxy coating paint with baked finished

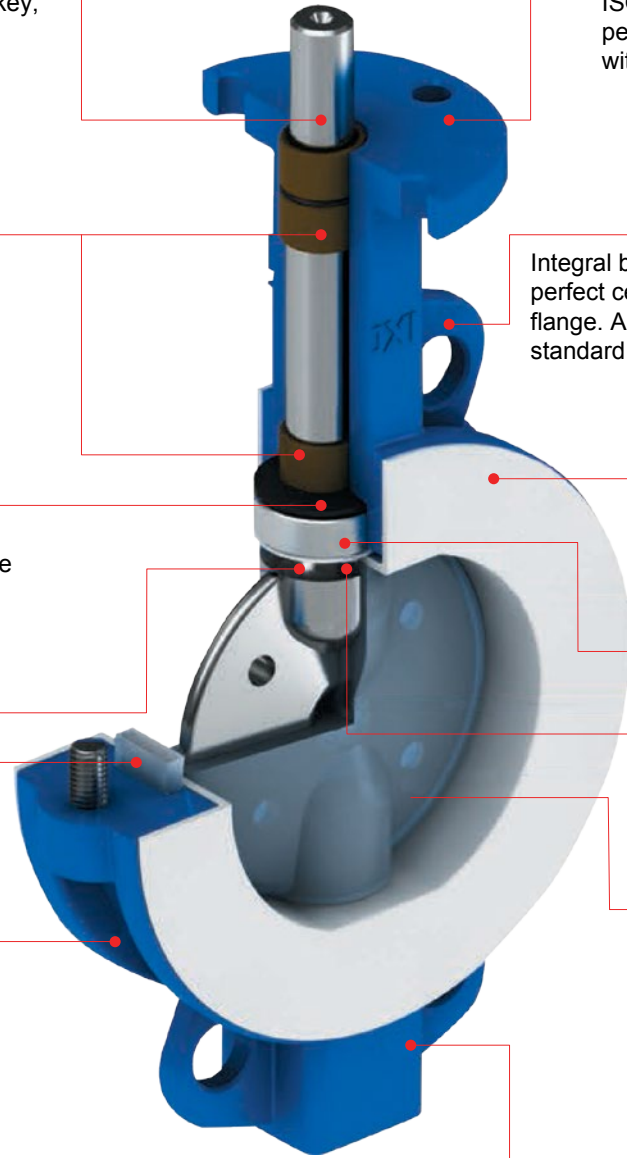

DIMENSION

DN	NPS	Dimensions in mm														A	ASME 150LB		JIS 10K		DIN Pn10		Weight [kg]	CV	Torque [N-m]
		mm	In	A	B	C	D	E	F	G	H	I	N-ø	L	K		X	Y	ISO 5211	ø D	Nt-ø1	ø D			
50	2	77	57	12.6	23	115	60	/	/	11	4-10	52	100	9	42	F07	120.7	4-19	120	4-19	125	4-18	2.2	210	25
65	1½	77	57	12.6	23	115	60	/	/	11	4-10	52	100	9	42	F07	139.7	4-19	140	4-19	145	4-18	2.2	210	25
80	3	92	70	12.6	26	150	86	/	/	11	4-10	46	135	18	66	F07	152.4	4-19	150	8-19	160	4-18	4.2	410	50
100	4	92	70	15.9	26	160	115	/	/	14	4-10	52	158	25	85	F07	190.5	8-19	175	8-19	180	8-18	6.4	710	80
125	5	92	70	15.9	26	175	130	/	/	14	4-10	56	185	35	112	F07	215.9	8-22	210	8-23	210	8-18	7.9	1150	90
150	6	115	89	22.2	28	192	145	/	/	17	4-14	56	210	48	139	F07	241.3	8-22	240	8-23	240	8-23	10.4	1750	130
200	8	115	89	22.2	28	220	175	/	/	17	4-14	60	263	69	187	F10	298.5	8-22	290	12-23	295	8-23	17	3550	180
250	10	140	108	31.8	35	275	215	/	/	24	4-14	68	320	90	237	F10	362	12-25	355	12-25	350	12-23	25	5100	400
300	12	140	108	31.8	35	310	250	/	/	24	4-14	78	368	112	290	F12	431.8	12-25	400	16-25	400	12-23	34.5	8870	610
350	14	210	165	38	55	360	285	33	10	/	4-22	78	410	136	341	F14	476.3	20-1 3/8	445	16-25	460	16-23	75	9200	850
400	16	210	165	38	55	395	320	33	10	/	4-22	102	460	147	383	F14	539.8	20-1 1/4	510	16-27	515	16-27	110	14500	1170
450	18	210	165	44	65	435	360	38.5	14	/	4-22	114	518	167	432	F14	577.9	16-1 1/4	565	20-27	/	/	130	20100	1560
500	20	210	165	44	65	435	385	38.5	14	/	4-22	127	565	181	473	F14	635	16-1 1/8	620	20-27	620	20-27	190	22000	1820
600	24	210	165	55	75	525	445	49	16	/	4-22	154	658	218	569	F14	749.3	12-1 1/8	730	24-33	725	204-30	280	31000	2990

LUG TYPE DIMENSION

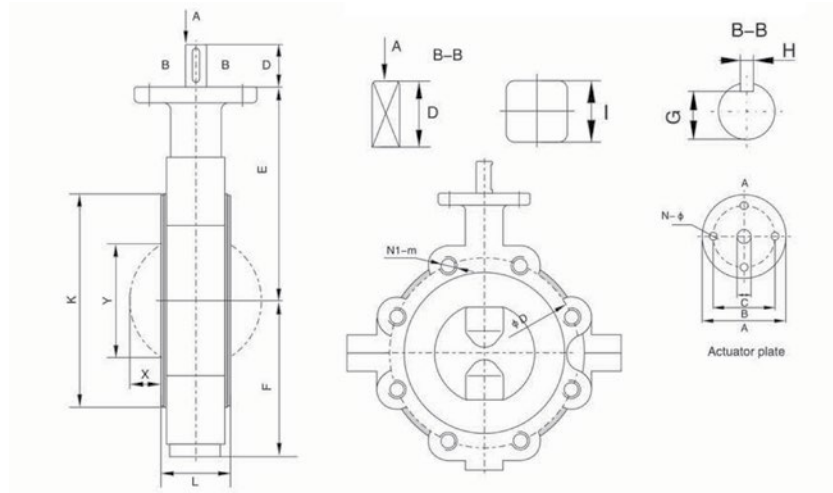

DN	NPS	Dimensions in mm														A	ASME B16.5		JIS B2212 10K		DIN2532 Pt10		Weight	CV	Torque
mm	In	A	B	C	D	E	F	G	H	I	N-∅	L	K	X	Y	ISO 5211	∅D	N1-m	∅D	N1-m	∅D	N1-∅1	[kg]		[N-m]
50	2	77	57	12.6	23	115	60	/	/	11	4-10	52	100	9	42	F07	120.7	4-5/8	120	4-16	125	4-M16	2.9	210	25
65	2½	77	57	12.6	23	115	60	/	/	11	4-10	52	100	9	42	F07	139.7	4-5/8	140	4-16	145	4-M16	2.9	210	25
80	3	92	70	12.6	26	150	86	/	/	11	4-10	46	135	18	66	F07	152.4	4-5/8	150	8-16	160	8-M16	5.5	410	50
100	4	92	70	15.9	26	160	115	/	/	14	4-10	52	158	25	85	F07	190.5	8-5/8	175	8-16	180	8-M16	8.3	710	80
125	5	92	70	15.9	26	175	130	/	/	14	4-14	56	185	35	112	F07	215.9	8-3/4	210	8-20	210	8-M16	10.3	1150	90
150	6	115	89	22.2	28	192	145	/	/	17	4-14	56	210	48	139	F07	241.3	8-3/4	240	8-20	240	8-M20	13.5	1750	130
200	8	115	89	22.2	28	220	175	/	/	17	4-14	60	263	69	187	F10	298.5	8-3/4	290	12-20	295	8-M20	22.1	3550	180
250	10	140	108	31.8	35	275	215	/	/	24	4-14	68	320	90	237	F10	362	12-7/8	355	12-22	350	12-M20	32.5	5100	400
300	12	140	108	31.8	35	310	250	/	/	24	4-14	78	368	112	290	F12	431.8	12-7/8	400	16-22	400	12-M20	44.9	8870	610
350	14	210	165	38	55	360	285	33	10	/	4-22	78	410	136	341	F14	476.3	12-1	445	16-22	460	16-M20	97	9200	850
400	16	210	165	38	55	395	320	33	10	/	4-22	102	460	147	383	F14	539.8	16-1	510	16-24	515	16-M24	143	14500	1170
450	18	210	165	44	65	435	360	38.5	14	/	4-22	114	518	167	432	F14	577.9	16-1 1/8	565	20-24	/	/	169	20100	1560
500	20	210	165	44	65	435	385	38.5	14	/	4-22	127	565	181	473	F14	635	20-1 1/8	620	20-24	620	20-M24	247	22000	1820
600	24	210	165	55	75	525	445	49	16	/	4-22	154	658	218	569	F14	749.3	20-1 1/4	730	24-30	725	20-M27	365	31000	2990

DIRECTION FOR THE USE OF VALVE

- Please, contact us when the SKY valves are used out of condition that writing this catalogue.
- PFA lined BUTTERFLY valve is sorted strategic goods. If you want to sell or export this valve, please make a declaration at the government and write down the vendor.
- In case using operating condition, please don't use this valve.
 - ⓐ melting alkali liquid and metal, a high temperature fluorine
 - ⓑ Including slurry ,or becoming stiff liquid.
- 본 CATALOGUE에 기재된 이외의 압력, 온도 및 특수한 유체조건등에서의 사용은 본사와 협의하여 제품을 선정하여 주시기 바랍니다.
- PFA LINED BALL VALVE는 전략물자로 분류되어 있으며, 이로인하여 국내판매시에는 그 사용처와 목적을 기재하여 관리하여야 하며, 해외수출시에는 지식경제부 산하 전략물자관리과의 통제 및 신고허가를 득 하여야 합니다.
- PFA 수지는 거의 모든 화학약품에 우수한 내식성을 가지고 있지만 하기와 같은 유체에는 적용이 어려울 수 있습니다.
 - ⓐ 용융 알칼리 금속과 용액, 고온의 불소와 불소화합물
 - ⓑ SLURRY를 함유하고 있는 용액, 또는 고착성(고체화)이 있는 유체

MAINTENANCE

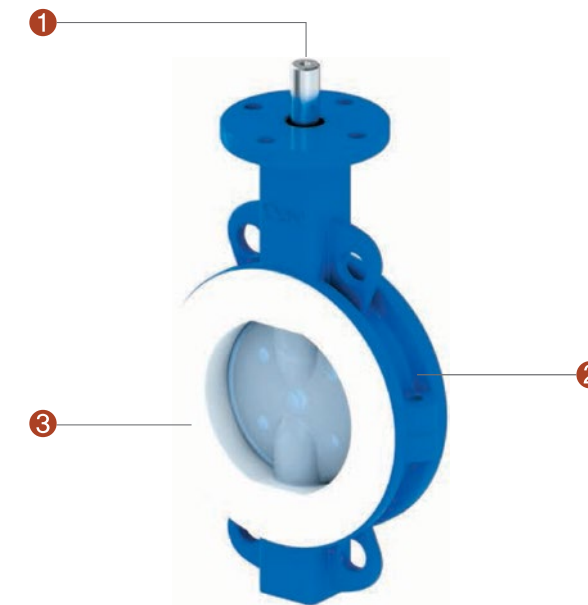

ORDERING INFORMATION

①	Model	Code	②	VALVE TYPE	Code	③	Operating	Code	④	Material	Code
	BUTTERFLY	BF		Wafer	W		Manual	M		Stainless	S
				Lug	L		Auto	A		Carbon steel	C
							Gear	G			
⑤	Surgace Finish	Code	⑥	DN Size(mm)		Ordering Example					
	Acid Cleaning	A				BF	W	M	S	A	100
	Painting	P			①	Model	BF				
					②	Valve Type	W				
					③	Operating		M			
					④	Material			S		
					⑤	Surface Finish				A	
					⑥	DN Size					100

Leak / Faulty (누수/고장)	Cause (원인)	Clearance (해결)
① Valve leaks (밸브 누수)	- STEM part faulty (스템부 부품고장)	- Replace STEM part item (STEM 부품 교체) - Replace valve (밸브 교체)
② Closes valvefluid passing (유체 누수)	- DISC faulty (DISC 고장) - PTFE liner faulty (PTFE 라이너 고장)	- DISC faulty : Replace DISC (DISC 교체) - PTFE liner faulty : Replace valve (밸브 교체)
③ Valve flare connection to piping leaks (배관연결 누수)	- Valve flaeer seal face faulty (밸브 플레어 면 불량) - Bolting faulty (볼팅 불량)	- Replace valve (밸브 교체) - Re-tighting bloting (재볼팅)